



**ABACO MACHINES**  
**OPERATION MANUAL**  
**ABACO GLASS LIFTER**



**ABACO MACHINES USA, INC.**  
20224 S. Normandie Ave.  
Torrance, CA 90502

Tel: 310-532-0366

Fax: 310-532-0499

Email: [sales@abacomachines.com](mailto:sales@abacomachines.com)

Website: [www.abacomachines.com](http://www.abacomachines.com)

# ABACO GLASS LIFTER

## I. SAFETY INSTRUCTIONS

### (A) For Abaco Glass Lifter

1. Carefully consider all safety regulations and existing standards in your country for hoisting operations.
2. Permission to work with the Abaco Glass Lifter should only be given to persons who are suitably trained, competent and acquainted with this operating manual and safety regulations.
3. Inspect the Abaco Glass Lifter. If the Abaco Glass Lifter is worn or damaged, do not use.
4. Select the proper size clamp for the job by determining the weight of the glass to be lifted. Do not exceed the W.L.L. (Working Load Limit) shown on the Abaco Glass Lifter.
5. All personnel must stand clear of the load while it is being lifted or moved.
6. The grip depends on friction. Check that the rubber pads are free from dirt, grease and other substances that may reduce their effectiveness.
7. Do not lift wet glass since the grip depends on friction. Lifting wet glass may cause the rubber pads to lose their grip.
8. No more than **one** piece of glass should be lifted at a time.
9. Position the Abaco Glass Lifter so that it is square with the glass to be lifted and in the center of the glass so that the load is balanced.
10. Make sure that the glass is inserted to the full depth into the opening of the Abaco Glass Lifter.
11. Take up the slack slowly. A trial tensioning of the load will usually indicate proper balance.
12. Do not lower the Abaco Glass Lifter onto other glass sheets or material while lowering glass into racks, as the clamp will release its load.

### (B) General Safety Instructions for Hoisting Accessories

**IMPORTANT!** In order to protect people from getting injured, it is important to follow some general safety directions while using hoisting accessories.

1. Read the operating manual carefully before you use hoisting accessories.
2. Make sure that the operating manual is always available where the hoisting accessories are used.
3. Give permission to work with hoisting accessories only to persons who are suitably trained and competent.
4. Wear safety equipment like a helmet, gloves, and safety boots.
5. **Never** leave a lifted load unsupervised.
6. Lift a load only as much as really necessary.
7. Do not get underneath a load, and do not permit others to do so.
8. Make sure all connections, bolts, and nuts are tight. Inspect these before **every** use.

9. Hoisting accessories must be stored in a place where they are protected against weather conditions and products that may be harmful to the accessories.
10. Defective hoisting accessories should no longer be used.
11. Repairs and checks are to be made only by qualified persons.

## II. INSTRUCTIONS FOR USE

1. Move the top glass sheet out from the pack of sheets allowing enough room for the Abaco Glass Lifter to be inserted. Do not move the glass sheet past the center of balance, and keep the glass sheet in an incline position.
2. Position the Abaco Glass Lifter squarely and in the center of the glass sheet so that the load is balanced.
3. Make sure that the glass sheet is inserted to the full depth into the opening of the Abaco Glass Lifter.
4. By lowering the Abaco Glass Lifter all the way onto the glass sheet, the Lifter will automatically click into **unlock**. The jaws will then move together and lock onto the glass sheet when the Abaco Glass Lifter is raised.
5. Lift the glass sheet **slowly** to ensure that the load is balanced.
6. Before lowering the load, make sure that there are no obstructions that the load to the Abaco Glass Lifter could unintentionally rest on. In this event, the lifter can drop the load.

## III. WARRANTY

At the time of delivery it is necessary to check that the Abaco Glass Lifter has not been damaged during shipment. Any claims must be presented within 8 days of the date of delivery of the product. We grant you 6 months warranty on the Abaco Glass Lifter from the day of purchase.

The warranty coverage is not applicable:

- When the Lifter is handled incorrectly during maneuvering.
- When the operator fails to comply with the instructions in this booklet.
- When the Lifter's maximum permissible capacity is exceeded.
- When the specifications for the glass sheet thickness are not followed.
- When damages are due to inadequate maintenance and inspections.
- When damage is due to improper storage.
- When repairs are performed to the Lifter by the user without our permission.
- When non-original spare parts are used.

#### IV. TECHNICAL SPECIFICATIONS

Model Number	Length Inches (mm)	Width Inches (mm)	Height Inches (mm)	Grip Range Inches (mm)	W.L.L. Pounds (kg)	Net Weight Pounds (kg)
AGL-28	23 $\frac{3}{8}$ (600)	9 $\frac{1}{2}$ (240)	24 $\frac{5}{8}$ (625)	$\frac{1}{8}$ -1 $\frac{1}{8}$ (4-28)	1320 (600)	57.2 (26)
AGL-38	29 $\frac{1}{8}$ (740)	10 (255)	28 (710)	$\frac{1}{8}$ -1 $\frac{1}{2}$ (4-38)	1650 (750)	72.6 (33)

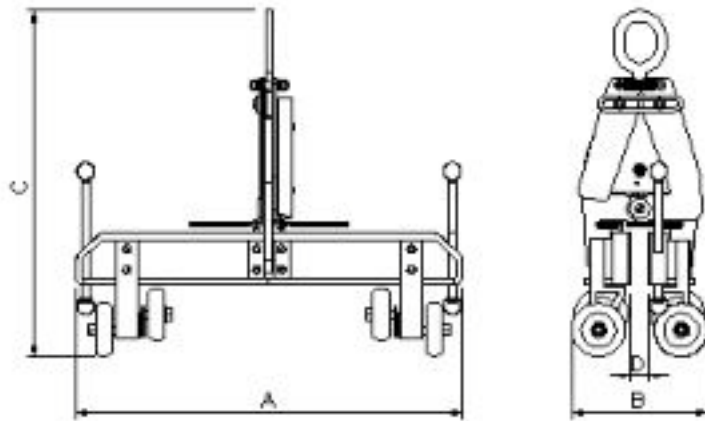

*Figure 1*

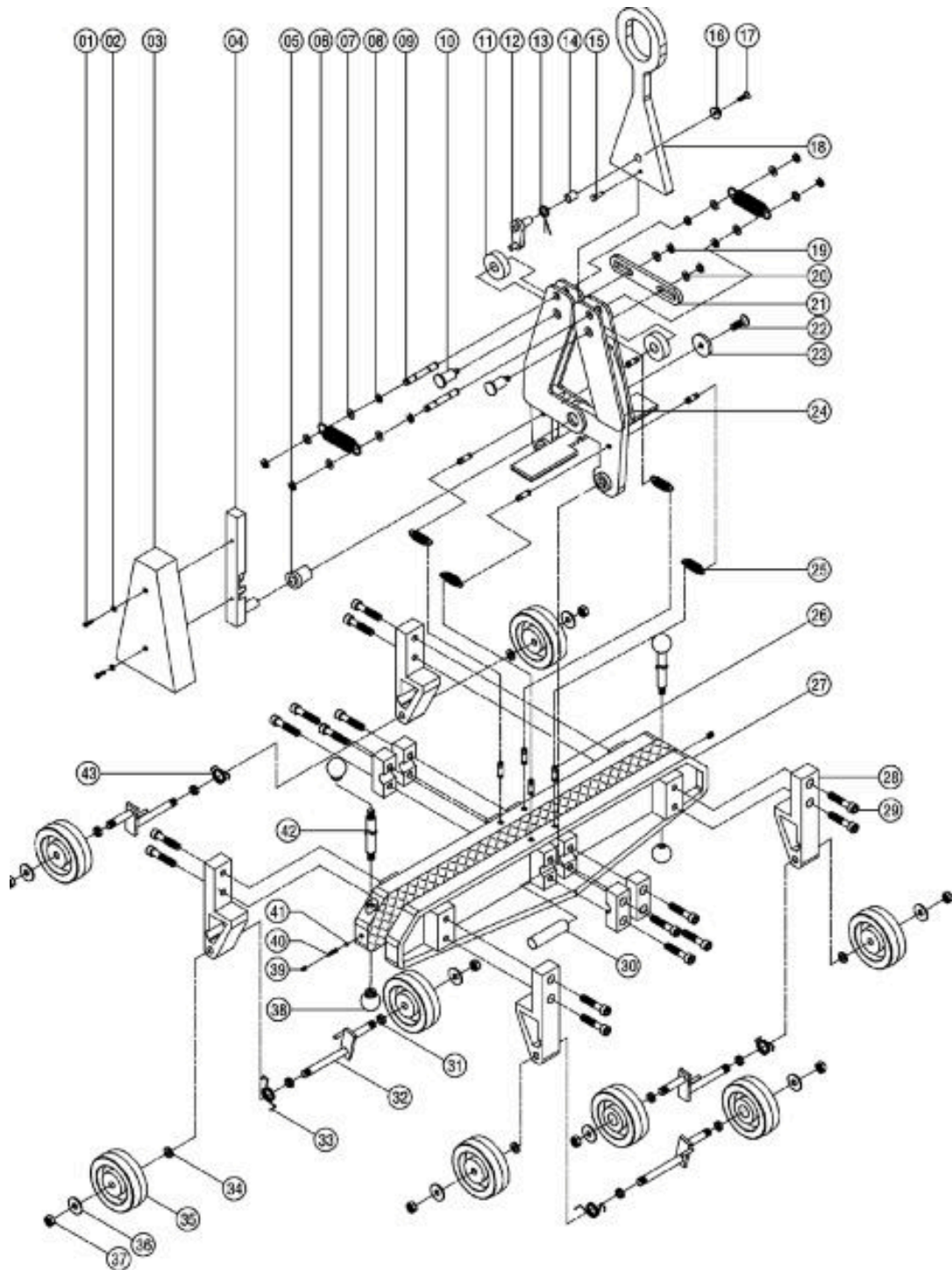

POS	DESCRIPTION	QTY	POS	DESCRIPTION	QTY
1	Socket Head M6 x 10	6	23	Washer ø8 x ø40 x 5	1
2	Washer ø6 x ø13 x 0.5	2	24	Main Arm	1
3	Protect Cover	1	25	Extension Spring	4
4	Locking Guide	1	26	Pressure Pad Spring Holder	8
5	Internal Spacer ø30 x ø16 x 35	1	27	Pressure Pad Spring Holder	2
6	Extension Spring	2	28	Guide Wheel Mounting	4
7	Aluminum Washer ø10xø16x0.5	8	29	Socket Head M10 x 30	16
8	External Circlip ø10	8	30	Linker Shaft	2
9	Spring Holder Pin	2	31	Spacer ø12 x ø16 x 5	8
10	Roller Pin	2	32	Z Shaft (Guide Wheel Shaft)	4
11	Roller	2	33	Torsion Spring Left	2
12	Locking Latch	1	34	Washer ø12 x ø18 x 1	4
13	Torsion Spring	1	35	Guide Wheel	8
14	Spacer ø14 x ø12 x 20	1	36	Washer ø12 x ø30 x 1	8
15	Location Pin	1	37	Nylon Nut M12	8
16	Washer ø20 x ø10 x 5	1	38	Guide Knob	2
17	Metal Screws M6 x 15	1	39	Set Screw M6 x 5	2
18	Lifting Pin	1	40	Compression Spring	2
19	Circlip ø12	2	41	Steel Ball	2
20	Aluminum Washer ø12 x ø22 x 0.5	3	42	Guide Rod	2
21	Extension Bracket	1	43	Torsion Spring Right	2
22	Metal Screw M8 x 20	1			

## V. ASSEMBLY INSTRUCTIONS

Attach guide wheels set (B) and (C) to pressure pad (A) by socket head cap screw M10 x 30 (29).

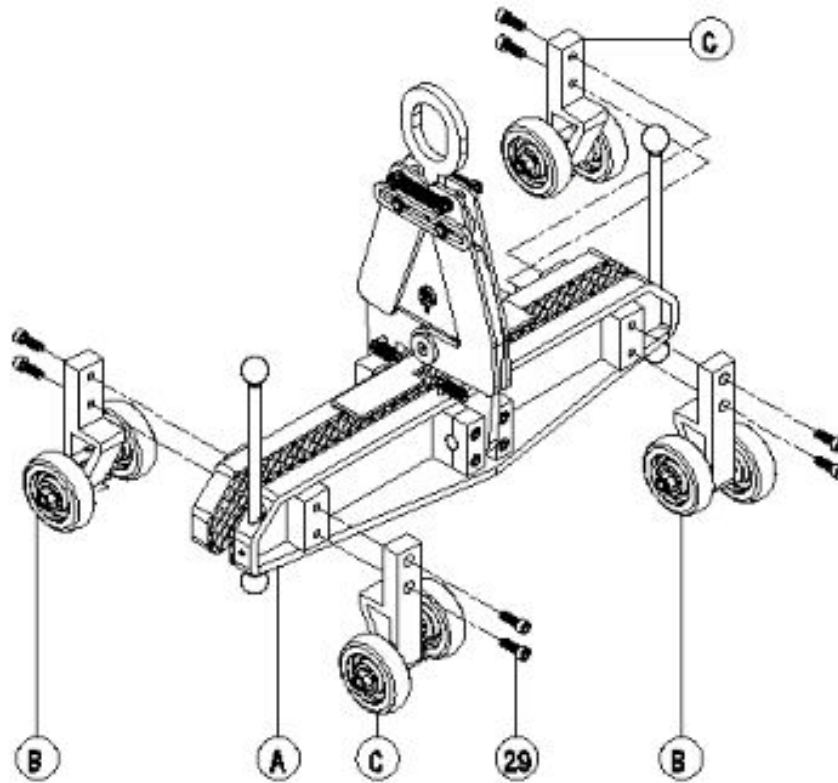

Figure 3

## VI. INSPECTION, MAINTENANCE, AND REPAIR

It is important to establish a regular procedure for Lifter inspection. Frequency of inspection will depend upon the amount of use the Lifter receives. You may wish to retain a written record, indicating inspection dates, conditioner of the Lifter on each of those dates, and any repairs made. Inspection records should be viewed periodically.

Always use original spare parts when carrying out repairs or maintenance.



## ABACO MACHINES

### WARRANTY CERTIFICATE

In order to validate the warranty, it is mandatory to return the attached **Warranty Certificate**, duly completed, within **eight** days after purchase.

#### PERIOD

The warranty starts from the date of purchase (date on the distributor's invoice).

Warranty is valid for a period of **six months**.

#### WARRANTY

This warranty is limited to the replacement of parts recognized as defective by Abaco (excluding worn components and consumables).

The manufacturer is not responsible for any direct or indirect, material or immaterial damages caused to persons or property by failure of the machine or the non-operation of the machine.

#### WARRANTY CONDITIONS

To benefit from the warranty, it is mandatory to return the Warranty Certificate (attached below), duly completed, to Abaco within eight days after purchase.

In case of failure of the machine during the warranty period, our After –Sales Service Department will inform you of the appropriate method of dealing with your claim and advise you of your nearest approved service center.

#### EXCLUSIONS

Warranty does not apply for damages or failures caused by:

- Incorrect use, misuse, error in transportation, handling or maintenance.
- Wear items such as the SHACKLE are not covered unless proven defective, but **not** from general wear.
- Use of non-genuine parts or accessories.
- Use of incorrect specifications, i.e. glass sheet thickness.

