



ABACO MACHINES
OPERATION MANUAL
ABACO 3 WHEEL SLAB DOLLY



ABACO MACHINES USA, INC.
(WEST COAST OPERATION)

20224 S. Normandie Ave.
Torrance, CA 90502

Tel: 310-532-0366
Fax: 310-532-0499

Email: sales@abacomachines.com
Website: www.abacomachines.com

ABACO MACHINES
INTERNATIONAL

Unit 4/34-36 Fairfield Street
Fairfield N.S.W. 2163 Australia

Tel: 61-2-9632-4990
Fax: 61-2-9632-1510

Email: abacomachines@abaco.com.au
Website: www.abaco.com.au

I. PRODUCT OUTLINE

The 3 Wheel Slab Dolly is designed to facilitate the handling and transporting of slabs on and around the worksite.

The rubber vulcanized channel protects the slabs from chipping and scratching.

It comes with pressurized wheels and a heavy duty locking brake swivel caster to provide additional stability and maneuvering in confined spaces.

The 3 Wheel Dolly is made in 2 sizes to meet your needs with the GD013 having a larger channel width of 4¾" (120mm).

II. STRUCTURE

The Dolly is constructed from a 3⅝" (80mm) to 4¾" (120mm) channel. It has a 13¾" (350mm) diameter pneumatic wheel and a 5" swivel caster.

SPECIFICATIONS

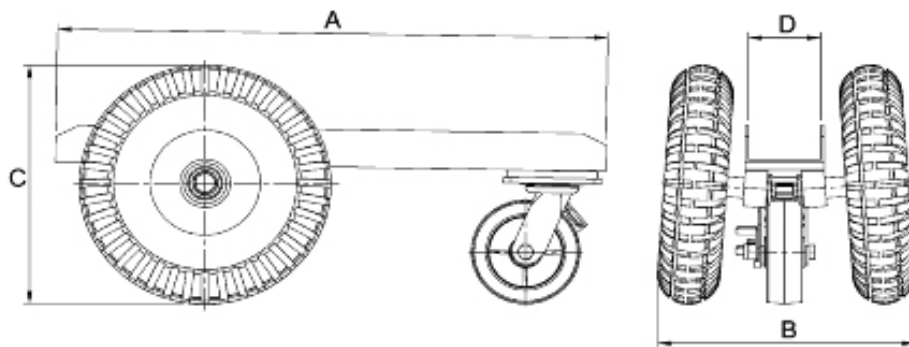

Model Number	A Inches (mm)	B Inches (mm)	C Inches (mm)	D Inches (mm)	Net Weight Pounds (kg)	W.L.L. Pounds (kg)
SD013	27⅝ (700)	12¾ (324)	13¾ (350)	3⅝ (80)	42 (19)	880 (400)
GD013	27⅝ (700)	14¾ (364)	13¾ (350)	4¾ (120)	42 (19)	880 (400)

III. ASSEMBLY INSTRUCTIONS

1. Insert the wheel shaft (03) into the body (02) by the bolt (07) and the washer (06).
2. Place the pneumatic wheels (04) onto the wheel shaft (03) with the washer (01) and secure them with the circlips (05).
3. Finally, fix the swivel caster (08) onto the body (02) by the bolt (07) and washers (09) and (10).

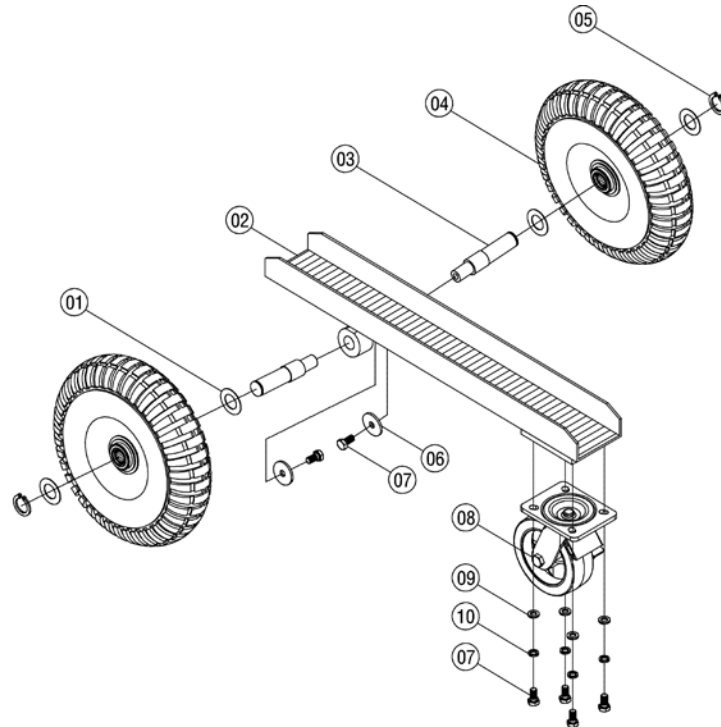

IV. SPARE PARTS

Number	Description	Qty.
1	Copper Washer $\varnothing 25\text{mm}$	4
2	Body	1
3	Wheel Shaft	2
4	Pneumatic Wheel $13\frac{3}{4}''$ ($\varnothing 350\text{mm}$)	2
5	External Circlip $\varnothing 25\text{mm}$	2
6	Washer $\varnothing 10\text{mm}$	2
7	Bolt M10 x 20	6
8	Swivel Caster 5"	1
9	Steel Washer $\varnothing 10\text{mm}$	4
10	Spring Washer $\varnothing 10\text{mm}$	4

V. INSTRUCTIONS FOR USE



When you want to move a panel, follow this procedure:

1. Use your foot to lock the swivel caster.
2. Place the panel, marble or granite, slightly off center so it can be easily transported.
3. Unlock the swivel caster.
4. **HOLD** the panel and move the Dolly to the desired location.

VI. MAINTENANCE AND INSPECTION

Regularly check the air pressure in the pneumatic wheels.
Lubricate the shafts and bearings monthly.

VII. WARRANTY

At the time of delivery, it is necessary to ensure that the Dolly has not been damaged during shipment. Any claims must be presented within eight (8) days of the date of delivery of the product.

We grant you six (6) months warranty on the Dolly counted from the day of purchase.

The warranty coverage is not applicable:

- When the Dolly has been misused.
- When the maximum capacity is exceeded.
- When damages are due to inadequate maintenance and inspections.
- When damages are due to improper storage.
- When repairs are performed by the user without our permission.
- When non-original spare parts are used.

